

# **User Manual**

Edition: 2011-02-23

## **K238**

### **Media- / DVI-Converter**

#### **Model:**

**K238-5V**

**K238-5VE**

**K238-5VS**

**K238-5FBNC**

#### **IHSE GmbH**

Maybachstrasse 11  
88094 Oberteuringen  
Germany

[info@ihse.de](mailto:info@ihse.de)

[www.ihse.de](http://www.ihse.de)

Tel. +49 7546-9248-0

Fax +49 7546-9248-48

### **Copyright**

© 2011. All rights reserved. This information may not be reproduced in any manner without the prior written consent of the manufacturer.

Information in this document is subject to change without notice.

### **Trademarks**

All trademark and trade names mentioned in this document are acknowledged to be the property of their respective owners.

### **Disclaimer**

While every precaution has been taken during preparation of this manual, the manufacturer assumes no liability for errors or omissions. Neither does the manufacturer assume any liability for damages resulting from the use of the information contained herein.

The manufacturer reserves the right to change specifications, functions, or circuitry of the product without notice.

The manufacturer cannot accept liability for damage due to misuse of the product or due to any other circumstances outside the manufacturer's control (whether environmental or installation related). The manufacturer shall not be liable for any loss, damage, or injury arising directly, indirectly, incidentally, or consequently from the use of this product.

# Contents

|          |   |           |
|----------|---|-----------|
| <b>1</b> | <b>About This Manual .....</b>                | <b>6</b>  |
|          | 1.1 Scope.....                                | 6         |
|          | 1.2 Validity .....                            | 6         |
|          | 1.3 Cautions and Notes .....                  | 6         |
| <b>2</b> | <b>Safety Instructions .....</b>              | <b>7</b>  |
| <b>3</b> | <b>Description .....</b>                      | <b>8</b>  |
|          | 3.1 Application .....                         | 8         |
|          | 3.2 System Overview .....                     | 9         |
|          | 3.3 Product Range .....                       | 10        |
|          | 3.4 Upgrade Kits .....                        | 10        |
|          | 3.5 Accessories.....                          | 11        |
|          | 3.6 Device Views .....                        | 12        |
|          | 3.6.1 Model K238-5V .....                     | 12        |
|          | 3.6.2 Model K238-5VE.....                     | 13        |
|          | 3.6.3 Model K238-5VS.....                     | 14        |
|          | 3.6.4 Model K238-5FBNC.....                   | 15        |
|          | 3.7 Status LEDs .....                         | 16        |
| <b>4</b> | <b>Installation .....</b>                     | <b>17</b> |
|          | 4.1 Package Contents.....                     | 17        |
|          | 4.2 System Setup.....                         | 18        |
|          | 4.3 Example Applications.....                 | 19        |
| <b>5</b> | <b>Configuration.....</b>                     | <b>20</b> |
|          | 5.1 Infrared Remote Control.....              | 20        |
|          | 5.2 On Screen Display (OSD).....              | 23        |
|          | 5.2.1 Main Menu Item 'Color Settings' .....   | 24        |
|          | 5.2.2 Main Menu Item 'Picture Settings' ..... | 26        |
|          | 5.2.3 Main Menu Item 'Input Settings' .....   | 29        |
|          | 5.2.4 Main Menu Item 'Output Settings' .....  | 30        |
|          | 5.2.5 Main Menu Item 'General Settings' ..... | 31        |

|          |  |           |
|----------|--|-----------|
| <b>6</b> | <b>Operation</b> .....                         | <b>35</b> |
| 6.1      | Optimization of Picture Settings .....         | 35        |
| 6.1.1    | Optimization of Output Settings .....          | 36        |
| 6.1.2    | Optimization of Input Settings .....           | 36        |
| 6.1.3    | Optimization of Picture Settings .....         | 37        |
| 6.2      | Download of DDC Information .....              | 37        |
| 6.2.1    | Download of DDC by Infrared Remote Control ... | 38        |
| 6.2.2    | Download of DDC via OSD .....                  | 38        |
| <b>7</b> | <b>Specifications</b> .....                    | <b>39</b> |
| 7.1      | Interfaces .....                               | 39        |
| 7.1.1    | DVI-D Single Link .....                        | 39        |
| 7.1.2    | DVI-I Single Link .....                        | 39        |
| 7.1.3    | S-Video (Y/C) .....                            | 39        |
| 7.1.4    | SDI Video .....                                | 39        |
| 7.1.5    | EGA (D-Sub 9) .....                            | 39        |
| 7.1.6    | Composite Video (BAS / FBAS) .....             | 40        |
| 7.1.7    | Component Video (YPbPr) .....                  | 40        |
| 7.1.8    | RGB Video .....                                | 40        |
| 7.2      | Supported Video Modes .....                    | 41        |
| 7.3      | Connector Pinouts .....                        | 49        |
| 7.4      | Power Supply .....                             | 52        |
| 7.5      | Environmental Conditions .....                 | 52        |
| 7.6      | Size .....                                     | 52        |
| 7.7      | Shipping Weight .....                          | 53        |
| <b>8</b> | <b>Troubleshooting</b> .....                   | <b>54</b> |
| 8.1      | Blank Screen .....                             | 54        |
| 8.2      | Picture .....                                  | 55        |
| 8.3      | General .....                                  | 55        |
| <b>9</b> | <b>Technical Support</b> .....                 | <b>56</b> |
| 9.1      | Support Checklist .....                        | 56        |
| 9.2      | Shipping Checklist .....                       | 56        |

|           |  |           |
|-----------|--|-----------|
| <b>10</b> | <b>Regulatory and Standards Compliance .....</b> | <b>57</b> |
| 10.1      | CE Declaration Of Conformity.....                | 57        |
| 10.2      | North American Regulatory Compliance .....       | 58        |
| 10.3      | WEEE .....                                       | 58        |
| 10.4      | RoHS .....                                       | 58        |
| <b>11</b> | <b>Glossary.....</b>                             | <b>59</b> |

# **1 About This Manual**

## **1.1 Scope**

This manual describes how to install your Media- / DVI-Converter, how to operate it and how to perform trouble shooting.

## **1.2 Validity**

This manual is valid for all devices listed on the front page. The product code is printed on the base of the devices.

## **1.3 Cautions and Notes**

The following symbols are used in this manual:



This symbol indicates an important operating instruction that should be followed to avoid any potential damage to hardware or property, loss of data, or personal injury.



This symbol indicates important information to help you make the best use of this product.

## 2 Safety Instructions

To ensure reliable and safe long-term operation of your Media- / DVI-Converter please note the following guidelines:

### **Installation**

- Only use in dry, indoor environments.
- The Media- / DVI-Converter and the power supply units can get warm. Do not situate them in an enclosed space without any airflow.
- Do not place the power supply directly on top of the device.
- Do not obscure ventilation holes.
- Only use power supplies originally supplied with the product or manufacturer-approved replacements. Do not use a power supply if it appears to be defective or has a damaged case.
- Connect all power supplies to grounded outlets. In each case, ensure that the ground connection is maintained from the outlet socket through to the power supply's AC power input.
- Do not connect the link interface to any other equipment, particularly network or telecommunications equipment.
- Take any required ESD precautions.

### **Repair**

- Do not attempt to open or repair a power supply unit.
- Do not attempt to open or repair the Media- / DVI-Converter. There are no user serviceable parts inside.
- Please contact your dealer or manufacturer if there is a fault.

# 3 Description

## 3.1 Application

The Media- / DVI-Converter is used to convert and output video signals of one or more video sources (computer, CPU, camera, DVD player) in the DVI-D format.

The Media- / DVI-Converter can be used as a switch between concurrently available input signals.

The Media- / DVI-Converter can further be used as a scaler, scaling video signals to a specific output format.

## 3.2 System Overview

The input ports of the Media- / DVI-Converter are connected to the video source(s) (e.g. computer, CPU, camera, DVD player, SPS control), using the provided cables or other suitable video cables.

The DVI-D monitor is connected to the output.

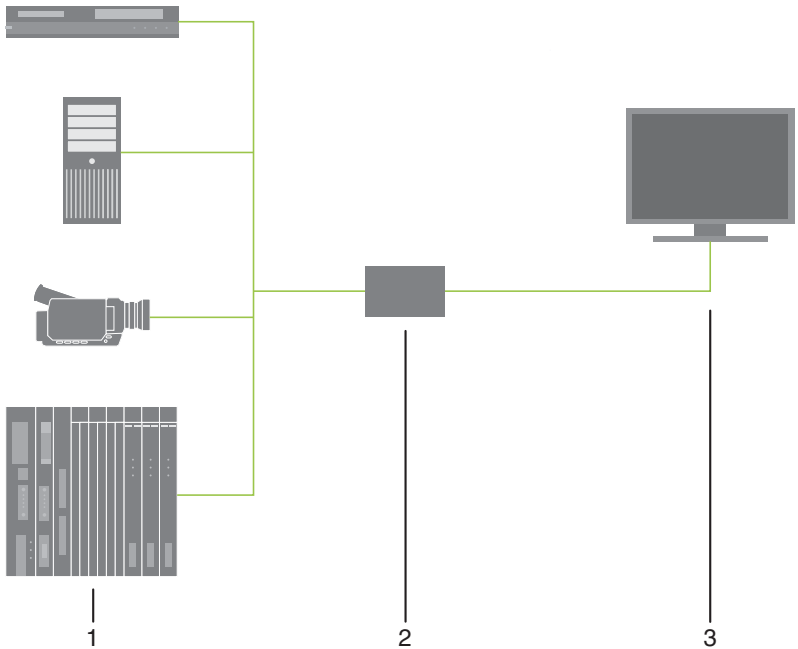

### *System Overview*

- 1 Sources (DVD player, computer, camera, SPS control)
- 2 Media- / DVI-Converter
- 3 Monitor



See Chapter 4.3, Page 19 for installation examples.

### 3.3 Product Range

| Model      | Description  |
|------------|--|
| K238-5V    | Media- / DVI-Converter for VGA- / DVI-Input (up to 1920x1200)  |
| K238-5VE   | Media- / DVI-Converter for VGA- / DVI-Input (up to 1920x1200) and Video (Y/C) / Component (YPbPr) / FBAS and CGA / EGA / MDA |
| K238-5VS   | Media- / DVI-Converter for VGA- / DVI-Input (up to 1920x1200) and Video (Y/C) / Component (YPbPr) / FBAS and (HD-)SDI        |
| K238-5FBNC | Media- / DVI-Converter for RGB- / VGA- / DVI-Input (up to 1920x1200) with a separate 5x BNC RGB-Input                        |



The input side of the following KVM extenders correspond to the Media- / DVI-Converter K238-5V: K477-xxxxV, L474-xxxxV.

### 3.4 Upgrade Kits

| Model  | Description   |
|--------|---|
| 455-4G | 19"/1U rack mount kit to mount up to 4 devices of type K238-5V                  |
| 455-8G | 19"/1U rack mount kit to mount up to 4 devices of type K238-5VE, -5VS or -5FBNC |
| 455-1K | Mounting plate to mount by screws (Typ K238-5V)                                 |
| 455-2K | Mounting plate to mount by snap on (Typ K238-5V)                                |
| 455-1G | Mounting plate to mount by screws (Typ K238-5VE, -5VS or -5FBNC)                |
| 455-2G | Mounting plate to mount by snap on (Typ K238-5VE, -5VS or -5FBNC)               |

### 3.5 Accessories

| Model   | Description  |
|---------|--|
| 238-BCA | Video adapter (BNC connector to Cinch connector)             |
| 238-BNC | RGB cable (2.0 m, 5x BNC connector)                          |
| 238-EGA | EGA cable (1.8 m, D-Sub 9 connector)                         |
| 238-IR  | Infrared remote control                                      |
| 238-RCA | Component video cable (1.5 m, 3x RCA connector)              |
| 238-SDI | SDI cable (1.8 m, BNC connector)                             |
| 238-SV  | S-Video cable (3.0 m, Mini-DIN connector, 4 pole)            |
| 260-5U  | International power supply unit 100...240VAC / 5VDC / 4 A    |
| 436-AA  | VGA cable (1.8 m, VGA connector to DVI-I connector)          |
| 436-DB1 | RGB / DVI cable (0.2 m, 5x BNC connector to DVI-D connector) |
| 436-ID  | DVI-D cable (1.8 m, DVI-D connector)                         |

## 3.6 Device Views

### 3.6.1 Model K238-5V

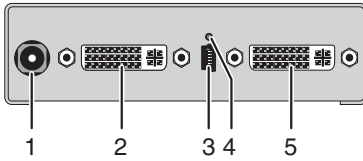

*Rear View*

- 1 Connect to 5VDC power supply
- 2 Input: DVI-I (VGA)
- 3 Service port
- 4 IR receiver for remote control
- 5 Output: DVI-D



*Front View*

- 1 IR receiver for remote control

### 3.6.2 Model K238-5VE

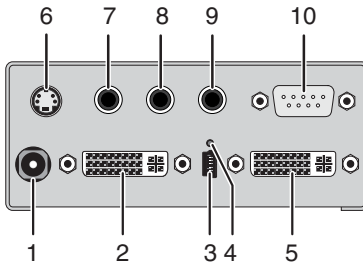

*Rear View*

- 1 Connect to 5VDC power supply
- 2 Input: DVI-I (VGA)
- 3 Service port
- 4 IR receiver for remote control
- 5 Output: DVI-D
- 6 Input: S-Video (Y/C)
- 7 Input: FBAS 1 or YPbPr (Pr)
- 8 Input: FBAS 2 or YPbPr (Y)
- 9 Input: FBAS 3 or YPbPr (Pb)
- 10 Input: EGA



*Front View*

- 1 IR receiver for remote control

## 3.6.3 Model K238-5VS

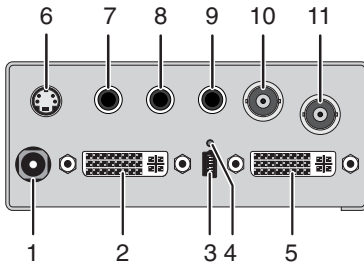

Rear View

- 1 Connect to 5VDC power supply
- 2 Input: DVI-I (VGA)
- 3 Service port
- 4 IR receiver for remote control
- 5 Output: DVI-D
- 6 Input: S-Video (Y/C)
- 7 Input: FBAS 1 or YPbPr (Pr)
- 8 Input: FBAS 2 or YPbPr (Y)
- 9 Input: FBAS 3 or YPbPr (Pb)
- 10 Input: FBAS 4
- 11 Input: (HD-)SDI



Front View

- 1 IR receiver for remote control

### 3.6.4 Model K238-5FBNC

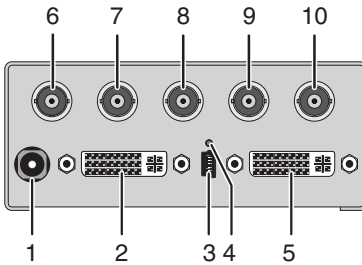

*Rear View*

- 1 Connect to 5VDC power supply
- 2 Input: DVI-I (VGA)
- 3 Service port
- 4 IR receiver for remote control
- 5 Output: DVI-D
- 6 Input: RGB (red)
- 7 Input: RGB (green)
- 8 Input: RGB (blue)
- 9 Input: RGB (H-/Compos. Sync)
- 10 Input: RGB (V-Sync)



*Front View*

- 1 IR receiver for remote control

## 3.7 Status LEDs

The Media- / DVI-Converter is fitted with a multi-color LED for indication of the connection status:

**K238-5V**

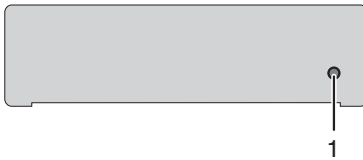

*Front View*

**K238-5VE / -VS / -FBNC**



*Front View*

### LED 1: Connection and Video Status

| LED color | Description for the input | Description for the output |
|-----------|---------------------------|----------------------------|
| Red       | No input signal           | Monitor detected           |
| Dark Red  | Resolution not supported  | Monitor not detected       |
| Green     | Active video signal       | Monitor not detected       |
| Blue      | No input signal           | Monitor detected           |
| Violet    | Resolution not supported  | Monitor detected           |
| Turquoise | Active video signal       | Monitor detected           |

## 4 Installation

### 4.1 Package Contents

Your Media- / DVI-Converter package contains the following items:

- Media- / DVI-Converter device
- 5VDC international power supply unit
- Country specific power cord
- Quick Setup
- VGA cable (1.8 m, VGA connector to DVI-I connector)



- Infrared remote control

**Additional content for K238-5VE:**

- EGA cable (1.8 m, D-Sub 9 connector)



- Component video cable (1.5 m, 3x RCA connector)



- S-Video (3.0 m, Mini-DIN connector, 4 pole)



**Additional content for K238-5VS:**

- SDI cable (2.0 m, BNC connector)



- Component video cable (1.5 m, 3x RCA connector)



- S-Video (3.0 m, Mini-DIN connector, 4 pole)



### Additional content for K238-5FBNC:

- RGB cable (2.0 m, 5x BNC connector).

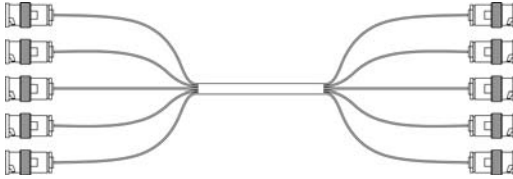

If anything is missing, contact your dealer.

## 4.2 System Setup



First time users are recommended to setup the system with the CPU Unit and the CON Unit in the same room as a test setup. This will allow you to identify and solve any cabling problems, and experiment with your system more conveniently.



➔ Please verify that interconnect cables, interfaces and handling of the devices comply with the requirements (see Chapter 7, Page 39).

1. Switch off all devices.
2. Connect the monitor to the Media- / DVI-Converter.
3. Connect the source (e.g. computer, video camera or control unit) to the Media- / DVI-Converter with the provided cables. Please ensure the cables are not strained.
4. Connect the provided 5VDC power supply to the Media- / DVI-Converter.
5. Power up the system.



To power up the system, the following sequence is recommended:  
Monitor – Media- / DVI-Converter – source.

## 4.3 Example Applications

This section illustrates typical installations of Media- / DVI-Converters:

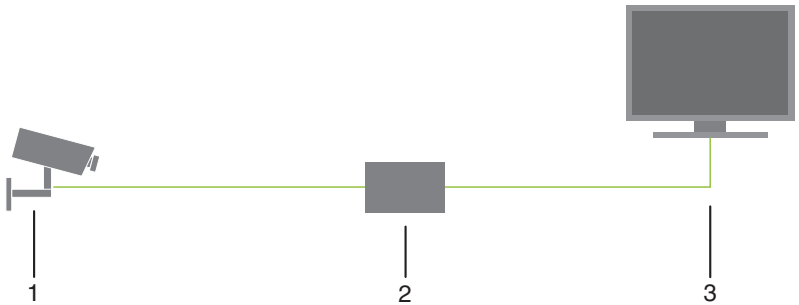

*Media- / DVI-Converter (Video Input: Composite)*

- 1 Source (observation camera)
- 2 Media- / DVI-Converter
- 3 Monitor

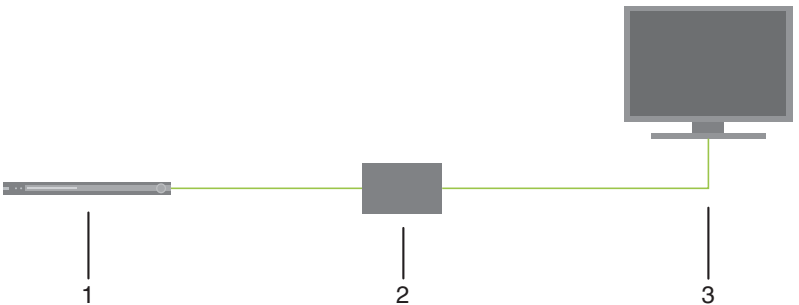

*Media- / DVI-Converter (Video Input: S-Video)*

- 1 Source (DVD player)
- 2 Media- / DVI-Converter
- 3 Monitor



# 5 Configuration







## 5.1 Infrared Remote Control



The Media- / DVI-Converter can be configured by an on screen display (OSD) and by an infrared remote control for the navigation through the menu items of the OSD.

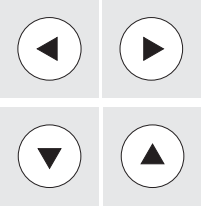

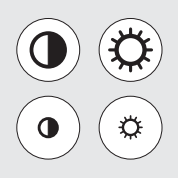
In the OSD, only the navigation keys of the infrared remote control are functional (red function key, key <↵>, key <EXIT>, key <ESC> and cursor keys <◀>, <▶>, <▲>, <▼>).

| Button  | Description              |
|---|--------------------------|
|  | Open OSD or select menu. |
|  | Open OSD or select menu. |

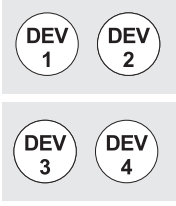
| Button  | Description   |
|---|---|
|    | Leave OSD.  |
|    | Leave current menu and open upper menu level.                               |
|    | Navigate inside the OSD.<br>Select parameters with cursor keys <◀> and <▶>. |
|    | Read and use DDC of the connected monitor.                                  |
|    | Adjust picture contrast / brightness.                                       |
|  | Reset the Media- / DVI-Converter to factory default.                        |
|  | Reset picture contrast / brightness to factory default.                     |

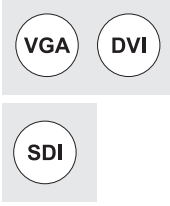
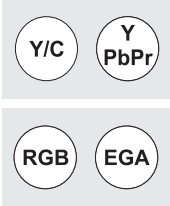
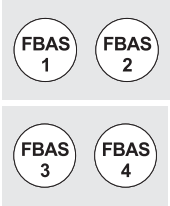
| Button   | Description  |
|--|--|
|  <p>Buttons: DEV 1, DEV 2, DEV 3, DEV 4</p>       | <p>If more than one converter is used:<br/>Select a single device for OSD access.</p>  |
|  <p>Button: DEV ALL</p>                           | <p>If more than one converter is used:<br/>Select all devices for OSD access.</p>  |
|  <p>Buttons: VGA, DVI, SDI</p>                    | <p>Select input signal: VGA, DVI or SDI.</p>   |
|  <p>Buttons: Y/C, Y PbPr, RGB, EGA</p>           | <p>Select input signal:</p> <ul style="list-style-type: none"> <li>• Y/C (S-Video)</li> <li>• YPbPr (Component Video)</li> <li>• RGB</li> <li>• EGA</li> </ul> |
|  <p>Buttons: FBAS 1, FBAS 2, FBAS 3, FBAS 4</p> | <p>Select input signal FBAS 1–3 (Cinch) or FBAS 4 (BNC).</p>   |

## 5.2 On Screen Display (OSD)

All settings of the Media- / DVI-Converter can be adjusted via the on screen display (OSD).

### General Structure of the OSD:

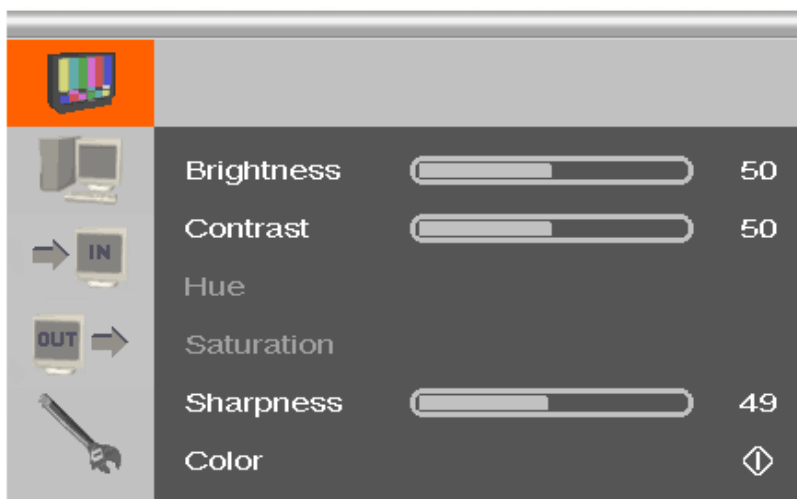

The left column shows the range of the main menu, the right column shows the current submenus with the respective configuration options.

The various configuration and setting options of the Media- / DVI-Converter are described below:

### 5.2.1 Main Menu Item 'Color Settings'

This menu offers color specific settings and configurations for the Media- / DVI-Converter.

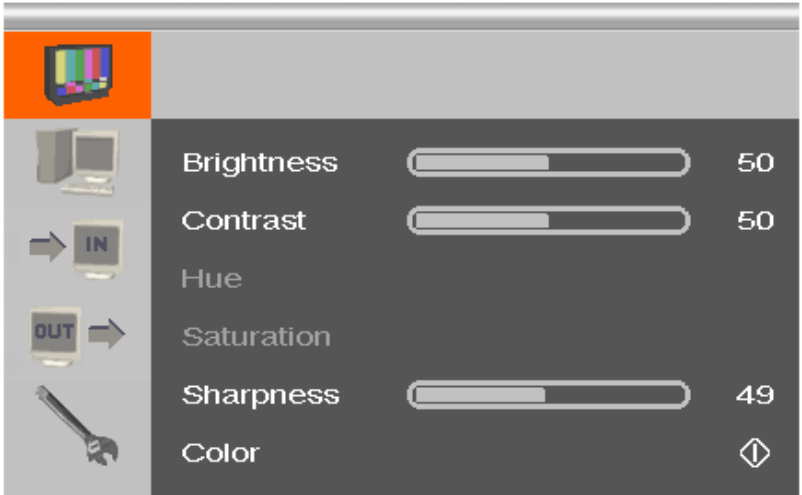

Menu View 'Color Settings'

| Menu Item  | Description  |
|------------|--|
| Brightness | Adjust brightness of the picture   |
| Contrast   | Adjust contrast of the picture   |
| Hue        | Change and adjust hue of the picture (only selectable in case of video input signals). |
| Saturation | Adjust saturation of the picture (only selectable in case of video input signals).     |
| Sharpness  | Adjust sharpness of the picture  |
| Color      | Open submenu 'Color' (see Chapter 5.2.1.1, Page 25).                                   |

## 5.2.1.1 Submenu 'Color'

This submenu offers advanced color settings for the picture (VGA / RGB / EGA input only).

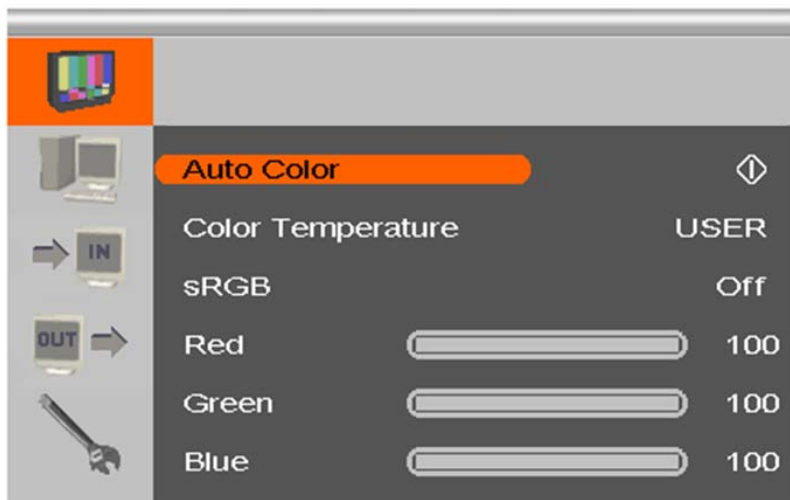

*Menu View 'Color'*

| Menu Item         | Description  |
|-------------------|--|
| Auto Color        | Adjust color values automatically  |
| Color Temperature | Adjust color temperature of the picture  |
| sRGB              | Activate the use of the standard RGB color range (Color optimization for tube monitors). |
| Red               | Adjust red color range   |
| Green             | Adjust green color range   |
| Blue              | Adjust blue color range  |

### 5.2.2 Main Menu Item 'Picture Settings'

This menu offers specific picture settings at the Media- / DVI-Converter.

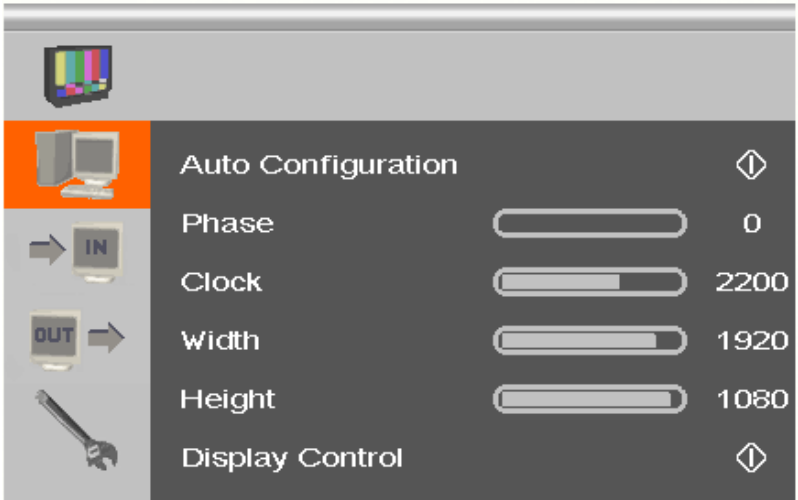

*Menu View 'Picture Settings'*

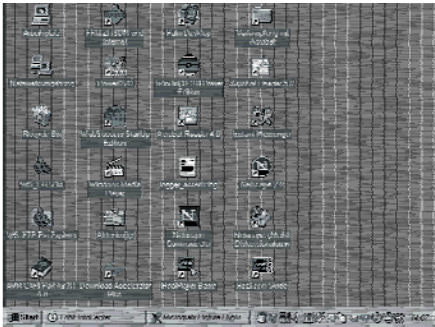
| Menu Item          | Description   |
|--------------------|---|
| Auto Configuration | Configure picture settings automatically (VGA / RGB / EGA input only).  |
| Phase              | Adjust pixel phase i.e. the best position for the analog / digital conversion within one pixel (VGA / RGB / EGA input only).<br><br><i>Example for a wrong pixel phase</i> |

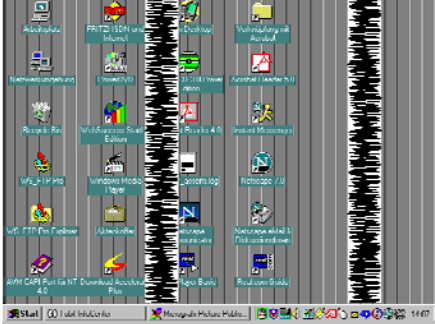
| Menu Item       | Description   |
|-----------------|---|
| Clock           | <p>Adjust pixel clock. The pixel clock shows the maximum number of the pixels that are horizontally displayable. Even non-visible and inactive pixels are counted in (VGA / RGB / EGA input only).</p>  <p><i>Example for a wrong pixel clock.</i></p> |
| Width           | Adjust width of the picture with the number of pixels.  |
| Height          | Adjust height of the picture with the number of pixels.   |
| Display Control | Open submenu 'Display Control' (see Chapter 5.2.2.1, Page 28).  |

### 5.2.2.1 Submenu 'Display Control'

This submenu offers control options for the display of the picture.

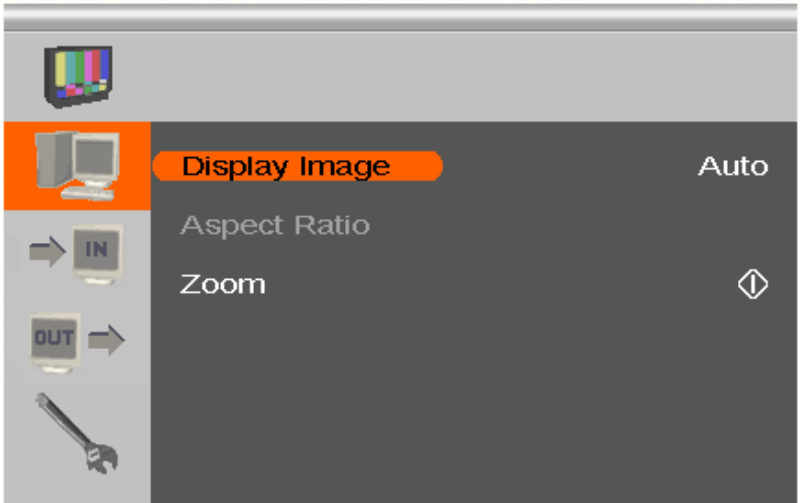

Menu View 'Display Control'

| Menu Item     | Description   |
|---------------|---|
| Display Image | Select display option: <ul style="list-style-type: none"> <li>'Auto': Scale picture automatically to the maximum value</li> <li>'Aspect': Adjust aspect ratio manually</li> <li>'1:1': Show picture in original size with a black border</li> </ul> |
| Aspect Ratio  | Select aspect ratio: 'Auto', '4:3', '14:9', '16:9' or '>16:9' (only if 'Display Image' is set to 'Aspect Ratio').   |
| Zoom          | Zoom picture and determine position of enlargement.   |

## 5.2.3 Main Menu Item 'Input Settings'

This menu offers specific settings for the input of the Media- / DVI-Converter.

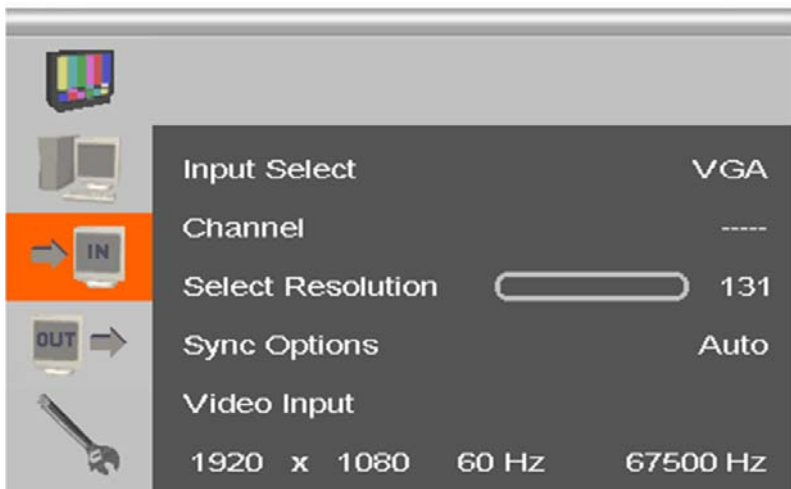

*Menu View 'Input Settings'*

| Menu Item         | Description  |
|-------------------|--|
| Input Select      | Select input signal  |
| Channel           | <ul style="list-style-type: none"> <li>For FBAS input signal:<br/>Select Composite channel.</li> <li>For EGA input:<br/>Select EGA, CGA or MDA input signal.</li> </ul>  |
| Select Resolution | Select video mode compatible to input signal (see Chapter 7.2, Page 41 for supported video modes).<br>Save settings by leaving the menu (monitor goes blank for a short time).   |
| Sync Options      | Select type of synchronization of the RGB signal. The type depends from the incoming RGB signal. <ul style="list-style-type: none"> <li>'Auto': Automatic adjustment</li> <li>'Composite (CS)' or 'Sync On Green (SOG)': Manual adjustment in case of picture failures (VGA / RGB input only)</li> </ul> |
| Video Input       | Display of selected video mode   |

## 5.2.4 Main Menu Item 'Output Settings'

This menu offers specific settings for the output of the Media- / DVI-Converter.



Menu View 'Output Settings'

| Menu Item        | Description  |
|------------------|--|
| Output           | Select output resolution: <ul style="list-style-type: none"> <li>'DDC': Use preferred resolution of the monitor's DDC at the output</li> <li>'Select': Select from predefined output resolutions in the menu item 'Resolution'</li> <li>'1:1': Use input resolution as output resolution</li> </ul>  |
| Resolution       | If 'Output' is set to 'Select': Select from predefined output resolutions.<br>A higher resolution can be selected at any time. If you select a lower resolution, the number of output pixels needs to comply with the following rule: <ul style="list-style-type: none"> <li>Horizontally: At least 50%</li> <li>Vertically: At least 33%</li> </ul> |
| Display Position | Adjust position of picture manually  |
| Video Output     | Display of the selected output resolution  |



For the scaling of the 1920x1200 resolution, restrictions apply.

## 5.2.5 Main Menu Item 'General Settings'

This menu offers general settings for the Media- / DVI-Converter.



Menu View 'General Settings'

| Menu Item       | Description  |
|-----------------|--|
| DDC             | Open submenu 'DDC' (see Chapter 5.2.5.1, Page 32).   |
| Miscellaneous   | Open submenu 'Miscellaneous' (see Chapter 5.2.5.2, Page 33).   |
| Device Address  | Assign device ID.<br>The device ID clearly identifies the device for the infrared remote control so that settings can be made for a specific device only.                                |
| Manage Settings | Write the existing device settings on the internal memory of the Media- / DVI-Converter ('Save'). These settings can be loaded again if required ('Load'), e.g. after a firmware update. |
| T-Adjust        | Compensate picture failures due to device temperature  |



Save device settings if you have made extensive settings or if you want to do a firmware update.

## 5.2.5.1 Submenu 'DDC'

This submenu offers DDC specific settings. DDC information is relevant for the output settings and for the connection to a computer or CPU.

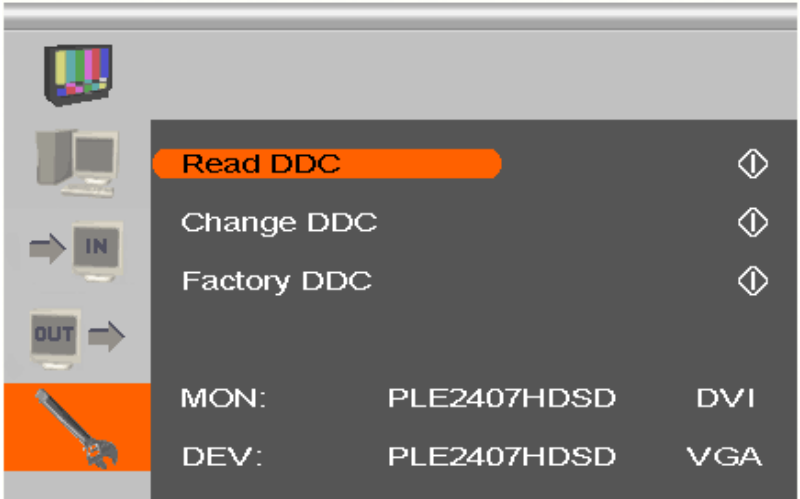

Menu View 'DDC'

| Menu Item   | Description   |
|-------------|---|
| Read DDC    | Use the monitor DDC as the device DDC and save it as DVI or VGA DDC.  |
| Change DDC  | Save the device DDC as DVI or VGA DDC   |
| Factory DDC | Use default DDC 'VGA2DVI' as device DDC   |
| MON:        | Display of name and type of the monitor DDC   |
| DEV:        | Display of name and type of the device's DDC that is provided at the DVI-I input by the Media- / DVI-Converter. |



When saving the DDC as DVI or VGA DDC, the selected type of DDC must match the video signal of the source (VGA or DVI) (see Chapter 5.2.3, Page 29: Menu item 'Input Select').

## 5.2.5.2 Submenu 'Miscellaneous'

This submenu offers various device specific settings.

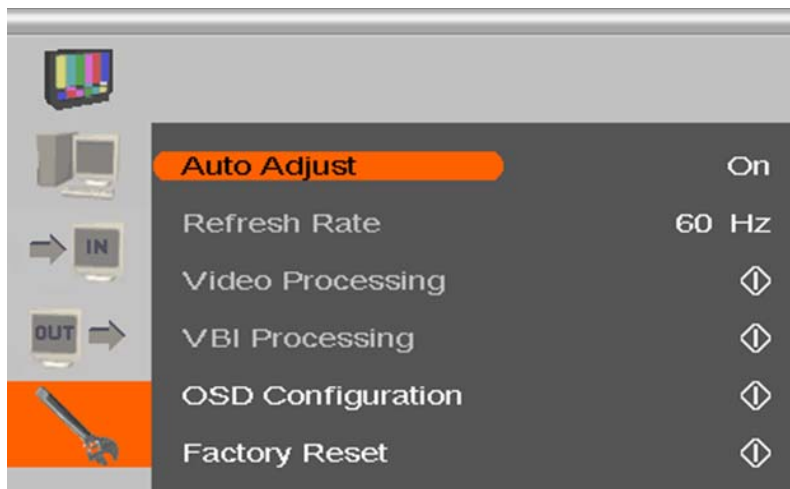

*Menu View 'Miscellaneous'*

| Menu Item         | Description   |
|-------------------|---|
| Auto Adjust       | Activate or deactivate the automatic configuration of the picture settings after changing the video mode. |
| Refresh Rate      | Change refresh rate if output is set to 'DDC'.  |
| Video Processing  | Not used  |
| VBI Processing    | Not used  |
| OSD Configuration | Configure OSD display on screen.  |
| Factory Reset     | Reset device to factory default (confirmation dialog)   |

## Submenu 'OSD Configuration'

This submenu offers various settings for the OSD display.



Menu View 'OSD Configuration'

| Menu Item        | Description   |
|------------------|---|
| OSD Timer        | Activate and select time of inactivity after which OSD is closed automatically. |
| OSD Position     | Adjust vertical and horizontal OSD position on screen.                          |
| OSD Transparency | Adjust OSD transparency   |
| OSD Zoom         | Activate scaling of OSD display   |

| Menu Item        | Description   |
|------------------|---|
| OSD Timer        | Activate and select time of inactivity after which OSD is closed automatically. |
| OSD Position     | Adjust vertical and horizontal OSD position on screen.                          |
| OSD Transparency | Adjust OSD transparency   |
| OSD Zoom         | Activate scaling of OSD display   |

## 6 Operation

### 6.1 Optimization of Picture Settings

All common video modes are pre-installed in an internal table of the Media- / DVI-Converter. If the input signal corresponds to one of these video modes, the signal will be automatically detected and the picture will be displayed.

If picture quality is not satisfying or no picture is displayed, proceed as follows:

1. Optimize the output settings (see Chapter 6.1.1, Page 36). Thus, the picture display will be adapted to the properties of the monitor.
2. Optimize the input settings (see Chapter 6.1.2, Page 36). Check if the automatically detected video mode corresponds to your input signal. Alternatively, you can manually select the most suitable video mode, even if you have an unknown input signal.
3. Optimize the picture settings for your input signal (see Chapter 6.1.3, Page 37).



In some cases it might happen that none of these measurements leads to a satisfying result. In this case fill in the video mode questionnaire ([Download](#)) so that a customer specific video mode can be created.

### 6.1.1 Optimization of Output Settings

1. If you have an analog input signal, display a picture with as much detail as possible on your graphic source, e.g. a text with black letters on a white ground (or vice versa).
2. Open the OSD with the infrared remote control.
3. Select 'Output Settings' in the main menu (see Chapter 5.2.4, Page 30).
4. Select the output resolution in the menu item 'Output':
  - Select 'DDC' to use the preferred resolution of the monitor DDC.
  - If the preferred resolution of the device DDC does not result in a satisfying picture, select 'Factory' and from the menu item 'Resolution' the most suitable resolution for the monitor.
5. Exit the OSD.

A window appears to save settings. This may take a few seconds.
6. Save the settings.

### 6.1.2 Optimization of Input Settings

For certain analog input signals (VGA / RGB / EGA), if the picture quality is not satisfying or no picture is displayed, you can select a video mode depending on the input signal.

1. Open the OSD with the infrared remote control.
2. Select 'Input Settings' in the main menu (see Chapter 5.2.3, Page 29).
3. Test the recommended resolutions that are listed in the menu item 'Select Resolution'. The menu item is inactive, if there is only one recommended resolution.
4. Run the automatic picture adjustment:
  - Select 'Picture Settings' in the main menu (see Chapter 5.2.2, Seite 26).
  - Select the menu item 'Auto Configuration'. Thereby picture size might change.
5. Check the test picture: If the vertical lines are displayed clearly, without smear or tremble, the setting has been successful.
6. Exit the OSD.

A window appears to save settings. This can take a few seconds.
7. Save the settings.

### 6.1.3 Optimization of Picture Settings

For certain analog input signals (VGA / RGB / EGA), if the picture quality is still not satisfying after the automatic picture adjustment, you can adjust clock and phase manually.

1. Select 'Picture Settings' in the main menu.
2. Modify the values in the menu items 'Clock' and 'Phase' until all failures have disappeared.
3. If the picture is displaced:
  - Select the menu item 'Display position' in the main menu item 'Output Settings' and position the picture in the upper left corner of the monitor.
  - Select the menu items 'Width' and 'Height' in the main menu item 'Picture Settings' and modify the values for width and height of the picture until the monitor is completely filled by the picture.
4. Exit the OSD.

A window appears to save settings. This can take a few seconds.
5. Save the settings.

## 6.2 Download of DDC Information

Loading DDC information is only relevant if you want to connect a DVI or VGA source. By default, the factory DDC information is reported to the source (computer, CPU). If these settings do not lead to a satisfying result, the DDC information of the connected monitor can be downloaded and stored internally.

There are two options to load the DDC information of the connected monitor:

- By means of the infrared remote control (see Chapter 6.2.1, Page 38).
- By means of the 'Read DDC' command in the OSD (see Chapter 6.2.2, Page 38).

### 6.2.1 Download of DDC by Infrared Remote Control

1. Press the <DDC> button on your infrared remote control.
2. Save the DDC as DVI or VGA DDC matching the input video signal.  
The DDC information of the connected monitor is saved in the Media- / DVI-Converter in the selected format.  
The source (computer, CPU) can read the DDC information of the monitor and display the available video resolutions.

### 6.2.2 Download of DDC via OSD

1. Open the OSD with the infrared remote control.
2. Select 'General Settings' in the main menu (see Chapter 5.2.5, Page 31).
3. Select the menu item 'Read DDC' in the submenu 'DDC'.
4. Save the DDC as DVI or VGA DDC matching the input video signal.  
The DDC information of the connected monitor is saved in the Media- / DVI-Converter in the selected format and is displayed at the bottom of the OSD menu under 'DEV:'.  
The source (computer, CPU) can read the DDC information of the monitor and display the available video resolutions.

## 7 Specifications

### 7.1 Interfaces

#### 7.1.1 DVI-D Single Link

The video interface supports the DVI-D protocol. All signals that comply to DVI-D Single Link norm can be transmitted. This includes e.g. monitor resolutions such as 1920x1200@60Hz, Full HD (1080p) or 2K HD (up to 2048x1152). Data rate is limited to 165 MPixel/s.

#### 7.1.2 DVI-I Single Link

The video interface supports the DVI-I protocol. All analog (VGA) or digital (DVI) signals that comply to DVI-I Single Link norm can be transmitted. This includes e.g. monitor resolutions such as 1920x1200@60Hz, Full HD (1080p) or 2K HD (up to 2048x1152). Data rate is limited to 165 MPixel/s.



Transmission of interlaced video signals, such as 1920x1080i, cannot be guaranteed.

#### 7.1.3 S-Video (Y/C)

The transmission of the video signal consists of a separate transmission of brightness and color information by two isolated signal and ground wire pairs. The plug connection consists of a 4-pole Mini-DIN connector with an input impedance of 75  $\Omega$ .

#### 7.1.4 SDI Video

The (HD-)SDI video signal is transmitted by a serial digital interface. The transmission is carried out uncoded and uncompressed via a coaxial cable. The voltage level of video signal is 0.8 Vpp.

#### 7.1.5 EGA (D-Sub 9)

The voltage level is a 5V TTL level.

The transmission of the video signal is carried out via a 9-pole D-Sub connector.

### 7.1.6 Composite Video (BAS / FBAS)

The (F)BAS signal is transmitted in an unmodulated form and consists of a brightness and synchronization signal, in case of FBAS also of an extra color signal.

The transmission of the analog video signal is carried out via a RCA (Cinch) or BNC (bayonet) plug connection.

### 7.1.7 Component Video (YPbPr)

The transmission of the analog video signals is carried out via three RCA connectors, whereby the first connector (Pr) transmits the color spectrum of the red and turquoise color range. The second connector (Y) transmits brightness and synchronization and the third connector (Pb) transmits the yellow and blue color range.

### 7.1.8 RGB Video

The video signal consists of R (red), G (green) and B (blue) signals. The voltage level of the video signal is 0.7 Vpp. The green signal can additionally contain the (Composite) synchronization signal. Furthermore, the interface is able to support RGBs and RGBHV video signals.

The communication of the video interface is carried out via a coaxial plug connection with a 5x bayonet lock (BNC).

## 7.2 Supported Video Modes

The following table lists the video modes that are recognized by the Media- / DVI-Converter (see Chapter 5.2.3, Page 29).



Video modes in italics will be recognized but not or not properly displayed.

### Video modes for DVI, VGA, EGA and RGB

| Index | Description           | Hres       | Vres       | V-Freq      | H-Freq      | Dot Clk     |
|-------|-----------------------|------------|------------|-------------|-------------|-------------|
| 17    | CGA(TTL)              | 320        | 200        | 59,9        | 15,7        | 7,2         |
| 10    | PAL                   | 416        | 574        | 50,0        | 15,6        | 8,0         |
| 36    | MONA S5               | 442        | 416        | 54,4        | 24,3        | 14,0        |
| 4     | AS 230 / 235 / OS 252 | 448        | 288        | 50,0        | 15,6        | 10,0        |
| 5     | GBE 3977-64x32        | 448        | 288        | 50,0        | 15,6        | 10,0        |
| 18    | DCC 555a              | 504        | 280        | 50,2        | 15,7        | 10,0        |
| 15    | WF470                 | 512        | 240        | 49,1        | 15,6        | 12,0        |
| 6     | WF470                 | 512        | 245        | 50,0        | 15,6        | 12,0        |
| 7     | WF470 / AS215         | 512        | 256        | 50,0        | 15,6        | 12,0        |
| 60    | WF470 / AS215         | 512        | 512        | 50,1        | 31,3        | 24,0        |
| 12    | GEM 80 graph i        | 560        | 224        | 25,0        | 15,6        | 11,7        |
| 24    | GEM 80 graph i        | 560        | 224        | 30,1        | 15,8        | 11,9        |
| 28    | GEM 80 graph i        | 560        | 224        | 37,5        | 18,2        | 12,0        |
| 45    | <i>750b</i>           | <i>560</i> | <i>248</i> | <i>41,6</i> | <i>26,0</i> | <i>20,0</i> |
| 8     | GBE3977 - 80x48       | 560        | 288        | 50,0        | 15,6        | 13,0        |
| 9     | DISET - 80x25         | 560        | 288        | 50,0        | 15,6        | 12,2        |
| 19    | DCS 560               | 560        | 288        | 50,0        | 15,7        | 11,4        |
| 44    | MONA -C               | 560        | 413        | 58,2        | 25,8        | 20,0        |
| 61    | GEM 80 graph progr.   | 560        | 448        | 50,1        | 31,3        | 23,5        |
| 64    | GEM 80 graph progr.   | 560        | 448        | 60,0        | 31,5        | 23,7        |
| 79    | GEM 80 graph progr.   | 560        | 448        | 75,1        | 36,4        | 24,0        |

## K238 Media- / DVI-Converter

| Index | Description        | Hres       | Vres       | V-Freq      | H-Freq      | Dot Clk     |
|-------|--------------------|------------|------------|-------------|-------------|-------------|
| 53    | WF480              | 580        | 480        | 59,9        | 30,6        | 25,0        |
| 22    | CGA(TTL)           | 640        | 200        | 59,9        | 15,7        | 14,3        |
| 3     | CP526/527          | 640        | 234        | 50,0        | 15,4        | 13,1        |
| 16    | GEM 80 text        | 640        | 288        | 48,8        | 15,6        | 13,0        |
| 47    | Prokon 2           | 640        | 288        | 83,0        | 27,4        | 23,0        |
| 34    | EGA (TTL)          | 640        | 350        | 59,8        | 21,9        | 16,3        |
| 162   | VGA                | 640        | 350        | 70,2        | 31,5        | 25,2        |
| 166   | VGA                | 640        | 350        | 84,9        | 37,8        | 31,4        |
| 33    | IVE 3              | 640        | 379        | 50,1        | 21,8        | 17,4        |
| 30    | IVE4               | 640        | 385        | 50,0        | 20,0        | 16,1        |
| 32    | Custom 1           | 640        | 385        | 49,9        | 20,6        | 16,5        |
| 39    | <i>ABB MOD 300</i> | <i>640</i> | <i>385</i> | <i>60,0</i> | <i>24,8</i> | <i>19,8</i> |
| 35    | IVE 2              | 640        | 398        | 50,0        | 21,9        | 17,8        |
| 52    | NEC 3D PGC         | 640        | 398        | 59,6        | 30,3        | 25,0        |
| 70    | XGA2               | 640        | 398        | 77,4        | 39,3        | 32,4        |
| 37    | VGA                | 640        | 400        | 55,9        | 24,6        | 20,9        |
| 49    | OP 398 K           | 640        | 400        | 60,0        | 27,5        | 22,2        |
| 164   | VGA                | 640        | 400        | 70,2        | 31,5        | 25,2        |
| 168   | VGA                | 640        | 400        | 84,9        | 37,8        | 31,4        |
| 38    | COROS LS-C         | 640        | 405        | 59,1        | 25,4        | 21,7        |
| 40    | COROS LS-C         | 640        | 405        | 59,1        | 25,4        | 21,7        |
| 42    | Prokon 1           | 640        | 432        | 53,8        | 25,5        | 23,1        |
| 48    | Prokon 3           | 640        | 432        | 58,9        | 27,4        | 23,0        |
| 56    | CP526 highres.     | 640        | 468        | 60,0        | 30,9        | 26,2        |
| 57    | CP528 highres      | 640        | 468        | 60,0        | 30,9        | 28,3        |
| 59    | CP526 highres      | 640        | 468        | 50,0        | 31,2        | 26,2        |

## Specifications

| Index | Description        | Hres       | Vres       | V-Freq      | H-Freq      | Dot Clk     |
|-------|--------------------|------------|------------|-------------|-------------|-------------|
| 54    | WF480 / Gracis     | 640        | 480        | 59,9        | 30,6        | 27,6        |
| 55    | DAMATIC            | 640        | 480        | 59,2        | 30,8        | 25,9        |
| 63    | VESA Standard      | 640        | 480        | 60,0        | 31,5        | 25,2        |
| 74    | MAC Mode           | 640        | 480        | 66,7        | 35,0        | 31,4        |
| 75    | MAC Mode           | 640        | 480        | 66,9        | 35,1        | 30,3        |
| 81    | VESA Standard      | 640        | 480        | 75,0        | 37,5        | 31,5        |
| 83    | VESA Standard      | 640        | 480        | 72,7        | 37,8        | 31,4        |
| 85    | VESA Standard      | 640        | 480        | 72,9        | 37,9        | 31,5        |
| 87    | VESA Standard      | 640        | 480        | 84,9        | 43,2        | 35,9        |
| 1     | NEC 15kHz          | 642        | 200        | 60,0        | 15,0        | 13,5        |
| 2     | NEC 15kHz i        | 642        | 200        | 30,0        | 15,0        | 13,5        |
| 65    | Std.-VGA           | 656        | 496        | 60,0        | 31,5        | 25,2        |
| 86    | NEC 42.5kHz        | 677        | 550        | 70,0        | 42,5        | 37,4        |
| 20    | NTSC (halfline)    | 680        | 240        | 59,9        | 15,7        | 12,9        |
| 23    | NTSC               | 680        | 480        | 59,9        | 15,7        | 12,9        |
| 25    | NTSC Interlaced    | 720        | 240        | 30,1        | 15,8        | 13,6        |
| 11    | PAL Interlaced     | 720        | 288        | 25,0        | 15,6        | 13,5        |
| 27    | <i>ABB DSAV110</i> | <i>720</i> | <i>336</i> | <i>50,1</i> | <i>17,9</i> | <i>15,6</i> |
| 29    | Hercules Monochrom | 720        | 350        | 49,7        | 18,4        | 16,2        |
| 72    | XGA2               | 720        | 350        | 87,8        | 39,4        | 35,5        |
| 163   | VGA                | 720        | 350        | 70,2        | 31,5        | 28,4        |
| 167   | VGA                | 720        | 350        | 84,9        | 37,8        | 35,4        |
| 31    | Custom 2           | 720        | 400        | 49,9        | 20,6        | 18,5        |
| 46    | NEC 27kHz          | 720        | 400        | 55,0        | 27,0        | 24,3        |
| 73    | XGA2               | 720        | 400        | 87,8        | 39,4        | 35,5        |
| 165   | VGA                | 720        | 400        | 70,2        | 31,5        | 28,4        |

## K238 Media- / DVI-Converter

| Index | Description       | Hres | Vres | V-Freq | H-Freq | Dot Clk |
|-------|-------------------|------|------|--------|--------|---------|
| 169   | VGA               | 720  | 400  | 85,0   | 37,9   | 35,5    |
| 41    | VDU 2000 Coros    | 720  | 405  | 59,1   | 25,4   | 24,5    |
| 43    | Teleperm / DS 078 | 720  | 408  | 60,0   | 25,7   | 23,1    |
| 66    | NTSC Progressive  | 720  | 480  | 60,0   | 31,5   | 27,0    |
| 71    | XGA2              | 720  | 480  | 74,9   | 39,3   | 35,4    |
| 62    | PC -Textmode      | 738  | 414  | 70,2   | 31,5   | 28,4    |
| 21    | MTBI              | 746  | 246  | 59,9   | 15,7   | 14,1    |
| 68    | GTF               | 768  | 576  | 60,0   | 35,8   | 34,9    |
| 88    | GTF               | 768  | 576  | 71,9   | 43,2   | 42,9    |
| 91    | GTF               | 768  | 576  | 74,9   | 45,1   | 45,5    |
| 104   | GTF               | 768  | 576  | 85,0   | 51,4   | 51,8    |
| 89    | NEC 44kHz         | 770  | 549  | 72,2   | 44,0   | 44,0    |
| 58    | CP 527/60         | 800  | 468  | 60,0   | 30,9   | 32,8    |
| 76    | VG900601          | 800  | 600  | 56,2   | 35,1   | 35,9    |
| 84    | VG900602          | 800  | 600  | 60,2   | 37,8   | 39,9    |
| 92    | VESA 600          | 800  | 600  | 74,9   | 46,8   | 49,4    |
| 96    | VS900603          | 800  | 600  | 72,1   | 48,0   | 49,9    |
| 106   | VESA Standard     | 800  | 600  | 84,9   | 53,6   | 56,2    |
| 100   | MAC Mode          | 832  | 624  | 75,0   | 49,5   | 55,4    |
| 101   | MAC Mode          | 832  | 624  | 74,5   | 49,7   | 57,3    |
| 80    | VESA Standard     | 960  | 600  | 60,1   | 37,4   | 46,0    |
| 77    | 768i              | 1024 | 384  | 43,0   | 35,5   | 44,9    |
| 78    | 768p              | 1024 | 768  | 86,8   | 35,5   | 44,9    |
| 98    | VG901101          | 1024 | 768  | 59,9   | 48,3   | 64,9    |
| 99    | MAC Mode          | 1024 | 768  | 59,9   | 48,7   | 63,9    |
| 112   | VS910801          | 1024 | 768  | 70,0   | 56,4   | 74,9    |

## Specifications

| Index | Description        | Hres | Vres | V-Freq | H-Freq | Dot Clk |
|-------|--------------------|------|------|--------|--------|---------|
| 113   | IBM                | 1024 | 768  | 72,1   | 57,5   | 75,0    |
| 114   | SUN Mode           | 1024 | 768  | 72,0   | 58,0   | 75,2    |
| 116   | VESA Standard      | 1024 | 768  | 75,0   | 60,0   | 78,7    |
| 117   | VESA Standard      | 1024 | 768  | 74,9   | 60,2   | 79,9    |
| 133   | VESA Standard      | 1024 | 768  | 84,9   | 68,6   | 94,4    |
| 108   | Custom Corus Group | 1024 | 864  | 60,0   | 54,3   | 73,0    |
| 69    | VESA Standard      | 1088 | 612  | 60,3   | 38,2   | 53,2    |
| 13    | DISET oversample   | 1120 | 288  | 50,0   | 15,6   | 24,5    |
| 107   | VESA Standard      | 1152 | 864  | 60,0   | 53,7   | 81,6    |
| 121   | DMT1185            | 1152 | 864  | 70,0   | 63,5   | 100,1   |
| 122   | VESA Standard      | 1152 | 864  | 70,0   | 63,8   | 94,4    |
| 130   | VESA Standard      | 1152 | 864  | 75,0   | 67,5   | 108,0   |
| 146   | GTF                | 1152 | 864  | 86,1   | 77,1   | 119,7   |
| 134   | Apple Mac II 2     | 1152 | 870  | 75,1   | 68,7   | 100,0   |
| 118   | SUN Mode           | 1152 | 900  | 66,0   | 61,8   | 94,4    |
| 119   | SUN Mode           | 1152 | 900  | 66,7   | 62,5   | 95,5    |
| 137   | NOKIA 447X         | 1152 | 900  | 76,0   | 71,7   | 105,5   |
| 14    | GBE3977 Oversample | 1164 | 288  | 50,0   | 15,6   | 26,0    |
| 50    | <i>1280i</i>       | 1280 | 512  | 25,0   | 28,0   | 44,6    |
| 82    | VESA CVT 16:9      | 1280 | 720  | 50,0   | 37,5   | 74,3    |
| 90    | VESA CVT 16:9      | 1280 | 720  | 59,9   | 44,8   | 74,5    |
| 94    | TV Mode            | 1280 | 768  | 60,0   | 47,7   | 80,1    |
| 97    | TV Mode            | 1280 | 768  | 60,0   | 48,1   | 81,2    |
| 102   | Beamer 16:10       | 1280 | 800  | 59,8   | 49,7   | 83,5    |
| 115   | VESA Standard      | 1280 | 960  | 60,0   | 60,0   | 108,0   |
| 139   | GTF                | 1280 | 960  | 72,0   | 72,1   | 124,6   |

## K238 Media- / DVI-Converter

| Index | Description          | Hres        | Vres       | V-Freq      | H-Freq      | Dot Clk     |
|-------|----------------------|-------------|------------|-------------|-------------|-------------|
| 143   | DMT 127A             | 1280        | 960        | 75,0        | 75,0        | 126,0       |
| 148   | GTF                  | 1280        | 960        | 77,3        | 77,5        | 133,9       |
| 156   | VESA Standard        | 1280        | 960        | 85,0        | 85,9        | 148,4       |
| 105   | TV Mode              | 1280        | 1024       | 50,1        | 53,4        | 90,1        |
| 120   | SONY GDM2036s        | 1280        | 1024       | 59,9        | 63,3        | 108,1       |
| 124   | VESA Standard        | 1280        | 1024       | 59,9        | 63,9        | 107,9       |
| 125   | Siemens SMI-5        | 1280        | 1024       | 60,0        | 64,0        | 112,6       |
| 135   | VESA Standard        | 1280        | 1024       | 67,0        | 70,7        | 119,9       |
| 138   | SUN Mode             | 1280        | 1024       | 66,7        | 71,7        | 117,0       |
| 147   | SXGA Unix            | 1280        | 1024       | 73,0        | 77,2        | 130,9       |
| 149   | HP Workstation B123L | 1280        | 1024       | 72,0        | 78,1        | 135,0       |
| 151   | VESA Standard        | 1280        | 1024       | 75,0        | 79,9        | 134,9       |
| 158   | VESA Standard        | 1280        | 1024       | 85,0        | 91,1        | 157,4       |
| 93    | TV Mode 16:9         | 1360        | 765        | 60,1        | 47,6        | 84,5        |
| 95    | Plasma TV 16:9       | 1360        | 768        | 60,0        | 47,7        | 85,5        |
| 127   | NVIDIA 4:3           | 1400        | 1050       | 59,7        | 65,0        | 121,2       |
| 150   | GTF                  | 1400        | 1050       | 72,0        | 78,8        | 149,4       |
| 153   | GTF                  | 1400        | 1050       | 75,0        | 82,2        | 155,9       |
| 26    | <i>NTSC</i>          | <i>1440</i> | <i>240</i> | <i>30,0</i> | <i>15,8</i> | <i>27,1</i> |
| 109   | TV Mode 16:10        | 1440        | 900        | 60,0        | 55,6        | 89,0        |
| 103   | 1200i                | 1600        | 600        | 40,0        | 50,0        | 108,0       |
| 110   | TV Mode 16:9         | 1600        | 900        | 59,9        | 55,8        | 118,7       |
| 123   | VESA Standard        | 1600        | 1024       | 60,2        | 63,8        | 136,8       |
| 142   | VESA Standard        | 1600        | 1200       | 60,0        | 75,0        | 162,0       |
| 144   | UXGA                 | 1600        | 1200       | 50,1        | 75,0        | 138,0       |
| 145   | UXGA rb              | 1600        | 1200       | 60,3        | 75,4        | 140,5       |

## Specifications

| Index | Description       | Hres        | Vres       | V-Freq      | H-Freq      | Dot Clk     |
|-------|-------------------|-------------|------------|-------------|-------------|-------------|
| 152   | VESA Standard     | 1600        | 1200       | 65,0        | 81,3        | 175,6       |
| 157   | VESA Standard     | 1600        | 1200       | 70,0        | 87,5        | 189,0       |
| 159   | VESA Standard     | 1600        | 1200       | 75,0        | 93,2        | 164,0       |
| 160   | VESA Standard     | 1600        | 1200       | 75,0        | 93,8        | 202,6       |
| 126   | WSXGA+ 16:10      | 1680        | 1050       | 59,9        | 64,7        | 119,0       |
| 128   | WSXGA+            | 1680        | 1050       | 60,1        | 65,4        | 146,5       |
| 154   | WSXGA+            | 1680        | 1050       | 74,9        | 82,3        | 187,0       |
| 161   | WSXGA+            | 1680        | 1050       | 85,0        | 93,9        | 214,8       |
| 155   | VESA Standard     | 1792        | 1344       | 60,0        | 83,6        | 204,7       |
| 51    | <i>1080i</i>      | <i>1920</i> | <i>540</i> | <i>25,0</i> | <i>28,1</i> | <i>74,2</i> |
| 67    | <i>1080i@60Hz</i> | <i>1920</i> | <i>540</i> | <i>30,0</i> | <i>33,8</i> | <i>74,4</i> |
| 111   | 1080p             | 1920        | 1080       | 49,7        | 55,9        | 147,6       |
| 129   | 1080p             | 1920        | 1080       | 59,7        | 66,8        | 172,1       |
| 131   | 1080p             | 1920        | 1080       | 60,0        | 67,5        | 148,5       |
| 140   | WUXGA             | 1920        | 1200       | 59,9        | 74,0        | 153,9       |
| 141   | WUXGA             | 1920        | 1200       | 59,6        | 74,2        | 192,3       |
| 132   | 2048*1080@60Hz    | 2048        | 1080       | 60,0        | 67,5        | 148,5       |
| 136   | 2048*1152@60Hz    | 2048        | 1152       | 59,9        | 71,0        | 156,8       |

## K238 Media- / DVI-Converter

### Video modes for Component- / Composite-Video, S-Video and SDI

| Description | FBAS | S-Video | Component | (HD-)SDI |
|-------------|------|---------|-----------|----------|
| 480i / 60Hz | X    | X       | X         | X        |
| 576i / 50Hz | X    | X       | X         | X        |
| 480p / 60Hz | –    | –       | X         | –        |
| 576p / 50Hz | –    | –       | X         | –        |
| 720p / 50Hz | –    | –       | X         | X        |
| 1080p       | –    | –       | –         | –        |

## 7.3 Connector Pinouts

### Connector DVI-D Single-Link

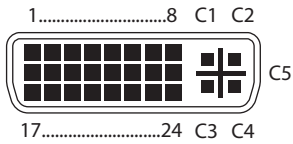

| Pin | Signal                | Pin | Signal                  | Pin | Signal                |
|-----|-----------------------|-----|-------------------------|-----|-----------------------|
| 1   | T.M.D.S data 2-       | 9   | T.M.D.S data 1-         | 17  | T.M.D.S data 0-       |
| 2   | T.M.D.S data 2+       | 10  | T.M.D.S data 1+         | 18  | T.M.D.S data 0+       |
| 3   | T.M.D.S data 2<br>GND | 11  | T.M.D.S data 1<br>GND   | 19  | T.M.D.S data 0<br>GND |
| 4   | n.c.                  | 12  | n.c.                    | 20  | n.c.                  |
| 5   | n.c.                  | 13  | n.c.                    | 21  | n.c.                  |
| 6   | DDC Input (SCL)       | 14  | +5VDC high<br>impedance | 22  | T.M.D.S clock<br>GND  |
| 7   | DDC Output<br>(SDA)   | 15  | GND                     | 23  | T.M.D.S clock +       |
| 8   | Internal use          | 16  | Hot Plug<br>recognition | 24  | T.M.D.S clock -       |
|     |                       |     |                         |     |                       |
| C1  | Internal use          |     |                         | C3  | Internal use          |
| C2  | n.c.                  | C5  | GND                     | C4  | Internal use          |

## Connector DVI-I Single-Link

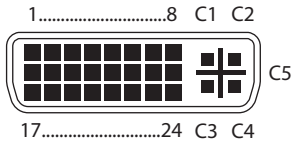

| Pin | Signal             | Pin | Signal               | Pin | Signal             |
|-----|--------------------|-----|----------------------|-----|--------------------|
| 1   | T.M.D.S data 2-    | 9   | T.M.D.S data 1-      | 17  | T.M.D.S data 0-    |
| 2   | T.M.D.S data 2+    | 10  | T.M.D.S data 1+      | 18  | T.M.D.S data 0+    |
| 3   | T.M.D.S data 2 GND | 11  | T.M.D.S data 1 GND   | 19  | T.M.D.S data 0 GND |
| 4   | n.c.               | 12  | n.c.                 | 20  | n.c.               |
| 5   | n.c.               | 13  | n.c.                 | 21  | n.c.               |
| 6   | DDC Input (SCL)    | 14  | +5VDC high impedance | 22  | T.M.D.S clock GND  |
| 7   | DDC Output (SDA)   | 15  | GND                  | 23  | T.M.D.S clock +    |
| 8   | Internal use       | 16  | Hot Plug recognition | 24  | T.M.D.S clock -    |
| C1  | Internal use       |     |                      | C3  | Internal use       |
| C2  | n.c.               | C5  | GND                  | C4  | Internal use       |

## RCA (Cinch)

| Picture | Pin | Signal        |
|---------|-----|---------------|
|         | 1   | GND           |
|         | 2   | Data IN / OUT |

## BNC (SDI, RGB)

| Picture   | Pin | Signal  |
|---|-----|---------|
|  | 1   | Data IN |
|   | 2   | GND     |

## Mini-DIN (S-Video)

| Picture   | Pin | Signal          |
|---|-----|-----------------|
|  | 1   | GND (Y)         |
|   | 2   | GND (C)         |
|   | 3   | Luminance (Y)   |
|   | 4   | Chrominance (C) |

## D-Sub 9 (EGA)

| Picture  | Pin | EGA         | CGA       | MDA       |
|--|-----|-------------|-----------|-----------|
|  | 1   | GND         | GND       | GND       |
|  | 2   | Red (LSB)   | –         | –         |
|  | 3   | Red (MSB)   | Red       | –         |
|  | 4   | Green (MSB) | Green     | –         |
|  | 5   | Blue (MSB)  | Blue      | –         |
|  | 6   | Green (LSB) | Intensity | Intensity |
|  | 7   | Blue (LSB)  | –         | Video     |
|  | 8   | H-SYNC      | H-SYNC    | H-SYNC    |
|  | 9   | V-SYNC      | V-SYNC    | V-SYNC    |

## Power Supply

| Picture   | Pin     | Signal      |
|---|---------|-------------|
| <br>5VDC | Inside  | VCC (+5VDC) |
|   | Outside | GND         |

## 7.4 Power Supply

|                   |  |
|-------------------|--|
| Voltage           | 5VDC   |
| Power Requirement | <ul style="list-style-type: none"><li>• K238-5V: max. 900 mA</li><li>• K238-5VE / -5VS / -5FBNC: max. 1,100 mA</li></ul> |

## 7.5 Environmental Conditions

|                       |                            |
|-----------------------|----------------------------|
| Operating Temperature | 41 to 113°F (5 to 45°C)    |
| Storage Temperature   | -13 to 140°F (-25 to 60°C) |
| Relative Humidity     | Max. 80% non-condensing    |

## 7.6 Size

### K238-5V

|                        |   |
|------------------------|---|
| Media- / DVI-Converter | 103 x 143 x 29 mm (4" x 5.6" x 1.1")    |
| Shipping Box           | 210 x 140 x 165 mm (8.3" x 5.5" x 6.5") |

### K238-5VE / -5VS / -5FBNC

|                        |  |
|------------------------|--|
| Media- / DVI-Converter | 103 x 143 x 43 mm (4" x 5.6" x 1.7")     |
| Shipping Box           | 460 x 250 x 120 mm (18.1" x 9.8" x 4.7") |

## 7.7 Shipping Weight

### K238-5V

|                               |                 |
|-------------------------------|-----------------|
| <b>Media- / DVI-Converter</b> | 0.3 kg (0.7 lb) |
| <b>Shipping Box</b>           | 1.8 kg (4.0 lb) |

### K238-5VE / -5VS / -5FBNC

|                               |                 |
|-------------------------------|-----------------|
| <b>Media- / DVI-Converter</b> | 0.4 kg (0.9 lb) |
| <b>Shipping Box</b>           | 2.3 kg (5.1 lb) |

## 8 Troubleshooting

### 8.1 Blank Screen

| Diagnosis           | Possible Reason                         | Measure   |
|---------------------|---|---|
| Status LED blue     | No video signal detected                | <ul style="list-style-type: none"> <li>➔ Check connections.</li> <li>➔ Check input selection in the OSD (source type).</li> <li>➔ Load DDC information of the connected monitor (see Chapter 6.2, Page 37).<br/>Reboot CPU if necessary.</li> </ul> |
| Status LED green    | No monitor detected                     | ➔ Check connection, length and quality of the DVI-D cable to monitor, tighten cable thumbscrews.  |
| Status LED dark red | No monitor detected                     | ➔ Check connection, length and quality of the DVI-D cable to monitor, tighten cable thumbscrews.  |
|                     | Resolution on device side not supported | ➔ Fill in the video mode questionnaire ( <a href="#">Download</a> ), so that a customer specific video mode can be made.  |
| Status-LED violet   | Resolution on device side not supported | ➔ Fill in the video mode questionnaire ( <a href="#">Download</a> ), so that a customer specific video mode can be made.  |

## 8.2 Picture

| Diagnosis                        | Possible Reason   | Measure   |
|----------------------------------|---|---|
| Incorrect picture display        | Connection between disturbed  | ➔ Check connection, length and quality of the DVI-D cable to monitor, tighten cable thumbscrews.  |
|                                  | Transmission parameters not suitable or not optimally set for conditions. | ➔ Run 'Auto Configuration' (see Chapter 5.2.2, Page 26).<br>➔ If necessary, set parameters for picture settings manually (e.g. phase and clock) (see Chapter 5.2.2, Page 26). |
| Parts of the picture are missing | Wrong setting of picture size   | ➔ Optimize picture settings (see Chapter 6.1, Page 35).   |
| Horizontal picture jitter        | Wrong settings of phase and clock   | ➔ Readjust phase and clock manually (see Chapter 5.2.2, Page 26).   |
| Characters are smeared           | Wrong setting of phase  | ➔ Readjust phase manually (see Chapter 5.2.2, Page 26).   |
| Fine vertical lines are missing  | Wrong setting of clock  | ➔ Readjust clock manually (see Chapter 5.2.2, Page 26).   |

## 8.3 General

| Diagnosis                                 | Possible Reason       | Measure  |
|---|-----------------------|--|
| Infrared remote control is non-functional | Wrong device selected | ➔ Press the button <DEV ALL> on the infrared remote control to get a device-independent access to the functions. |

# 9 Technical Support

Prior to contacting support please ensure you have read this manual, and then installed and set-up your Media- / DVI-Converter as recommended.

## 9.1 Support Checklist

To efficiently handle your request it is necessary to complete our checklist for support and problem cases ([Download](#)). Keep the following information available before you call:

- Company, name, phone number and email
- Type and serial number of the device (see bottom of device)
- Date and number of sales receipt, name of dealer if necessary
- Issue date of the existing manual
- Nature, circumstances and duration of the problem
- Involved components (such as graphic source/CPU, OS, graphic card, monitor, USB-HID/USB 2.0 devices, interconnect cable) including manufacturer and model number
- Results from any testing you have done

## 9.2 Shipping Checklist

1. To return your device, contact your dealer to obtain a RMA number (Return-Material-Authorization).
2. Package your devices carefully, preferably using the original box. Add all pieces which you received originally.
3. Note your RMA number visibly on your shipment.



Devices that are sent in without a RMA number cannot be accepted. The shipment will be sent back without being opened, postage unpaid.

## 10 Regulatory and Standards Compliance

### 10.1 CE Declaration Of Conformity

The products listed below in the form as delivered comply with the provisions of the following European Directives:

2004/108/EG Council Directive on the approximation of the laws of the Member States relating to electromagnetic compatibility



CE Marking 2009

Product list:

K238-5V, K238-5VE, K238-5VS, K238-5FBNC

The products comply with the following harmonized standards for Information Technology Equipment:

- EN 55022:2006 + A1:2007 (Class A)
- EN 55024:1998 + A1:2001 + A2:2003

This declaration certifies the conformity to the specified directives but contains no assurance of properties. The safety instructions and installation guidelines noted in this manual shall be considered in detail. Compliance with the specifications for cable lengths and types is mandatory.

Manufacturer:

IHSE GmbH  
Maybachstrasse 11  
88094 Oberteuringen  
Deutschland

Oberteuringen, 26 January 2010

The Management



#### Use in a Domestic Environment

This is a Class A product. In a domestic environment, this product may cause radio interference in which case the user may be required to take adequate measures.

### 10.2 North American Regulatory Compliance

This equipment has been found to comply with the limits for a Class A digital device, pursuant to Part 15 of the FCC Rules. These limits are designed to provide reasonable protection against harmful interference when the equipment is operated in a commercial environment. This equipment generates, uses, and can radiate radio frequency energy and, if not installed and used in accordance with the instruction manual, may cause harmful interference to radio communications. Operation of this equipment in a residential area is likely to cause harmful interference in which case the user will be required to correct the interference at his own expense.

Changes or modifications not expressly approved by the party responsible for compliance could void the user's authority to operate the equipment.

Shielded cables must be used with this equipment to maintain compliance with radio frequency energy emission regulations and ensure a suitably high level of immunity to electromagnetic disturbances.

All power supplies are certified to the relevant major international safety standards.

### 10.3 WEEE

The manufacturer complies with the EC Directive 2002/96/EG on the prevention of waste electrical and electronic equipment (WEEE).

The device labels carry a respective marking.

### 10.4 RoHS

This device complies with the EC Directive 2002/95/EG on the Restriction of the use of certain Hazardous Substances in electrical and electronic equipment (RoHS).

The device labels carry a respective marking.

# 11 Glossary

The following terms are commonly used in this guide or in video and KVM technology:

| Term            | Explanation   |
|-----------------|---|
| Cat X           | Any Cat 5e (Cat 6, Cat 7) cable   |
| CGA             | The Color Graphics Adapter (CGA) is an old analog graphic standard with up to 16 displayable colors and a maximum resolution of 640x400 pixels.   |
| Component Video | The Component Video (YPbPr) is a high-quality video standard that consists of three independently and separately transmittable video signals, the luminance signal and two color difference signals.  |
| Composite Video | The Composite Video is also called FBAS and it is part of the PAL TV standard.  |
| CON Unit        | Component of a Media- / DVI-Converter or Media Extender to connect to the console (monitor(s), keyboard and mouse; optionally also with USB 2.0 devices)  |
| CPU Unit        | Component of a Media- / DVI-Converter or Media Extender to connect to a source (computer, CPU)  |
| DDC             | The Display Data Channel (DDC) is a serial communication interface between monitor and source (computer, CPU). It allows a data exchange via monitor cable and an automatic installation and configuration of a monitor driver by the operating system. |
| Dual Access     | A system to operate a source (computer, CPU) from two consoles  |
| Dual-Head       | A system with two video connections   |
| Dual-Link       | A DVI-D interface for resolutions up to 2560x2048 by signal transmission of up to 330 MPixel/s (24-bit)   |
| DVI             | Digital video standard, introduced by the Digital Display Working Group ( <a href="http://www.ddwg.org">http://www.ddwg.org</a> ). Single Link and Dual Link standard are distinguished. The signals have TMDS level.                                   |
| DVI-I           | A combined signal (digital and analog) that allows running a VGA monitor at a DVI-I port – in contrast to DVI-D (see DVI).  |
| Fiber           | Single-mode or multi-mode fiber cables  |

| <b>Term</b>   | <b>Explanation</b>   |
|---------------|--|
| EGA           | The Enhanced Graphics Adapter (EGA) is an old analog graphic standard, introduced by IBM in 1984. A D-Sub 9 connector is used for connection.  |
| FBAS          | The analog color video baseband signal (FBAS) is also called Composite Video and it is part of the PAL TV standard.  |
| Console       | Keyboard, mouse and monitor  |
| KVM           | Keyboard, video and mouse  |
| Mini-XLR      | Industrial standard for electrical plug connections (3 pole) for the transmission of digital audio and control signals   |
| Multi-mode    | 62.5 $\mu$ multi-mode fiber cable or 50 $\mu$ multi-mode fiber cable   |
| OSD           | The On-Screen-Display is used to display information or to operate a device.   |
| Quad-Head     | A system with four video connections   |
| RCA (Cinch)   | A not standardized plug connection for transmission of electrical audio and video signals, especially with coaxial cables  |
| SFP           | SFPs (Small Form Factor Pluggable) are pluggable interface modules for Gigabit connections. SFP modules are available for Cat X and fiber interconnect cables.                         |
| Single-Head   | A system with one video connection   |
| Single Link   | A DVI-D interface for resolutions up to 1920x1200 by signal transmission of up to 165 MPixel/s (24-bit). Alternative frequencies are Full HD (1080p), 2K HD (2048x1080) and 2048x1152. |
| Single-mode   | 9 $\mu$ single-mode fiber cable  |
| S-Video (Y/C) | The S-Video (Y/C) is a video format transmitting luminance and chrominance signals separately. Thereby it has a higher quality standard than FBAS.                                     |
| TOSLINK       | Standardized fiber connection system for digital transmission of audio signals (F05 plug connection)   |
| Triple-Head   | A system with three video connections  |

| Term    | Explanation  |
|---------|--|
| USB-HID | <p>USB-HID devices (Human Interface Device) allow for data input.</p> <p>There is no need for a special driver during installation; "New USB-HID device found" is reported.</p> <p>Typical HID devices include keyboards, mice, graphics tablets and touch screens. Storage, video and audio devices are <b>not</b> HID.</p> |
| VGA     | <p>Video Graphics Array (VGA) is a computer graphics standard with a typical resolution of 640x480 pixels and up to 262,144 colors. It can be seen as a follower of the graphics standards MDA, CGA and EGA.</p>   |